

# ESPECIFICACIONES TÉCNICAS

PW-8246



PUMPOWER®

REFERENCIA	PW-8246	DOS ETAPAS
POTENCIA	23,19 HP / 17,30 kW	
TENSIÓN REQUERIDA / FRECUENCIA	220 V o 440 V a 60 Hz / TRIFÁSICO	
NIVEL PRESIÓN ACÚSTICA	78 dB (A)	
MÁXIMO FLUJO DE AIRE (Q.MAX)	620 m <sup>3</sup> /h	
CAUDAL MÁXIMO (CFM)	364,92 pie <sup>3</sup> /min	
VACÍO MÁXIMO	-490 mBar	
PRESIÓN MÁXIMA	750 mBar	
	10,88 psi	
	0,75 Bar	
	75,0 kPa	
PROFUNDIDAD MAX.	7,5 m.c.a. [metro columna de agua]	
VELOCIDAD	3545 rpm	
DIÁMETROS: ENTRADA / SALIDA	2,5 pulg. X 2,5 pulg.	
AMP. CON CARGA	220V 34,5 A / 440V 19,9 A.	
PESO	120 kg	
DIMENSIONES CAJA	73 cm x 57 cm x 62 cm	

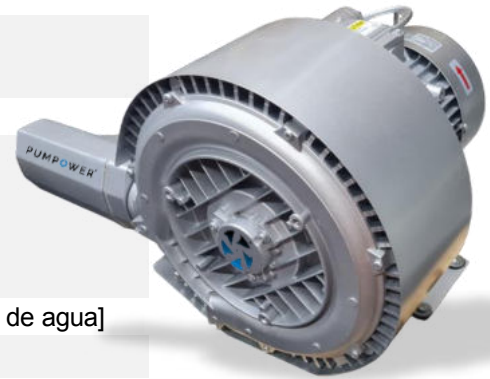

#### Dimension for Side Channel Blower

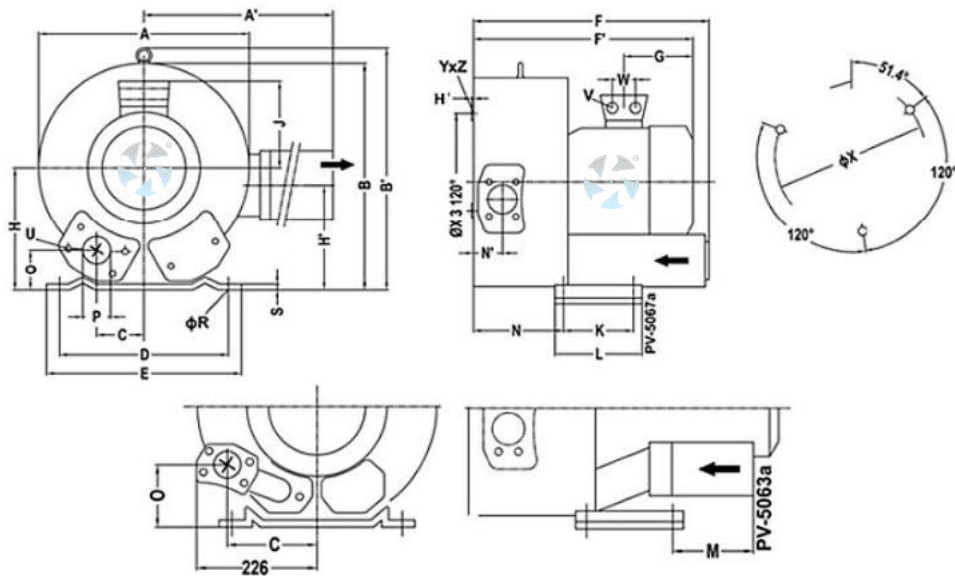

Type	Phases	A	A'	B	C	D	E
PW-8246	3~	500	549	490	152	356	394
F	F'	G	H	H'	J	K	L
545	694	318	240	199	197	170	217
M	N	O	P	φR	S	V	W
—	212	105	G 2 ½	15	6	4×M40×1.5	54
φX	Y_Z	X-Holes					
286	M12×20	51.4°/120°/240°					

Note: Model offerings and design parameters may change without notice.

# PW-8246

Performance curve for Vacuum pump

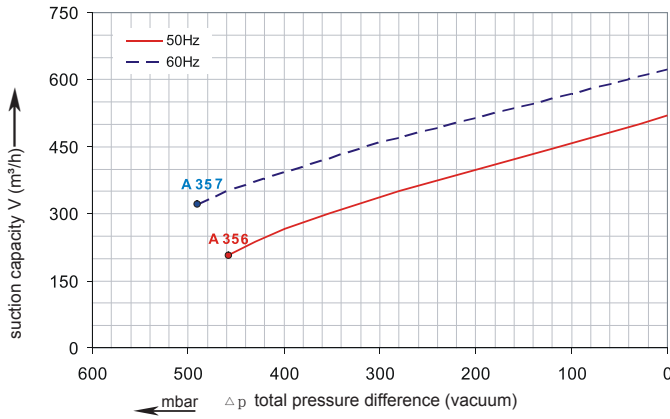

Performance curve for Compressor

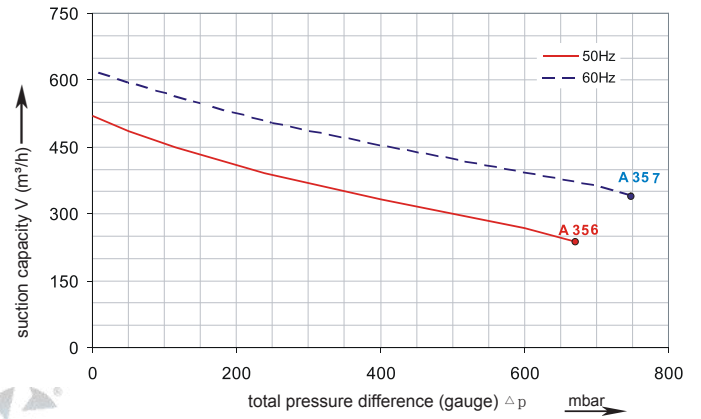

PUMPOWER

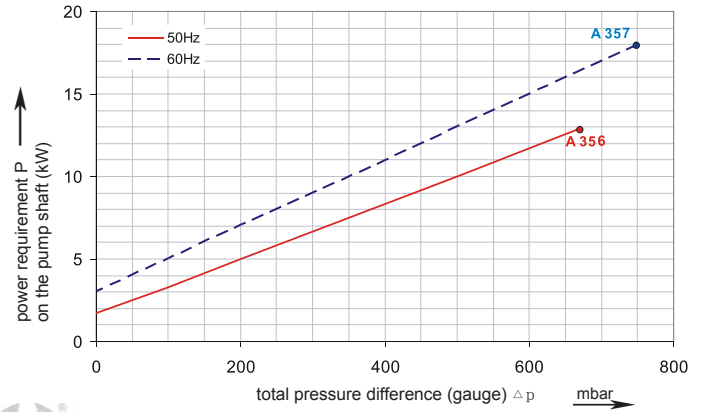
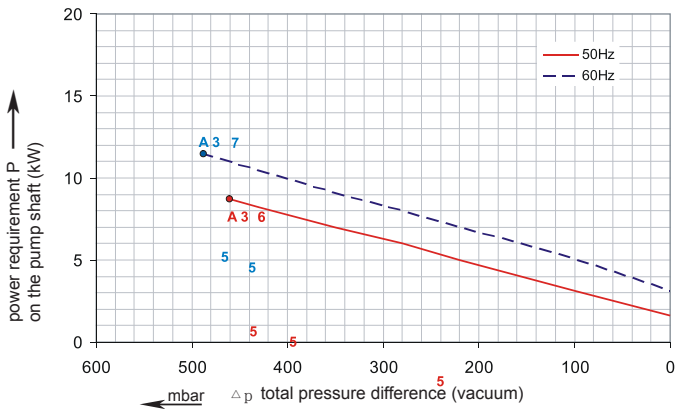

PUMPOWER

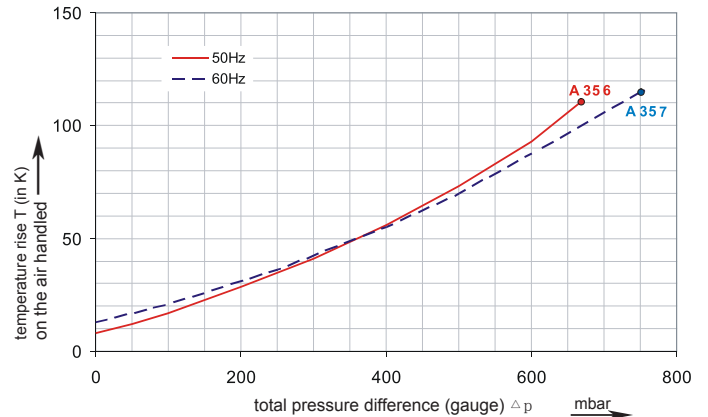
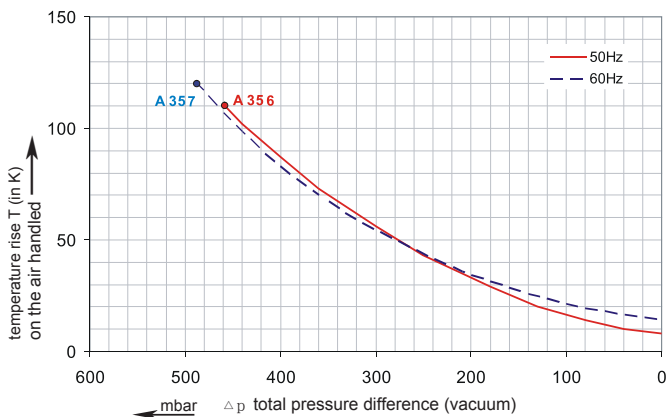

The performance curves are based on air at a temperature of 15 °C and an atmospheric pressure of 1013 mbar with a tolerance of +/- 10 %. The total pressure differences are valid for suction and ambient temperatures up to 25 °C. For other conditions please confer with us.

Each PW type can be applied both as vacuum pump and compressor in continuous operation over the total stated performance curve range. The motors are available as standard for the input voltage range of 50 and 60 Hz and for protection category IP 55.

**Selection and ordering data**
**Type PW-8246**

Curve No.	Order No.	Fre- quency	Rated power	Input voltage		Input current		Permissible total differential pressure <sup>2)</sup>		Sound pressure level <sup>3)</sup>	Weight ca.
				Hz	kW	V		Vacuum mbar	Compressor mbar		
<b>3~ 50/60 Hz IP55 isulation material class F 1)</b>											
A 356	PW-8246	50	15.0	200D ... 240D	345Y...415Y	56.5D	32.5Y	-460	670	74	120
A 357	PW-8246	60	17.3	220D ... 275D	380Y...480Y	60.0D	34.5Y	-490	750	78	120

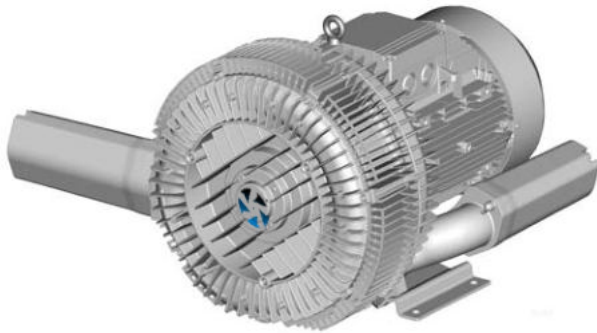
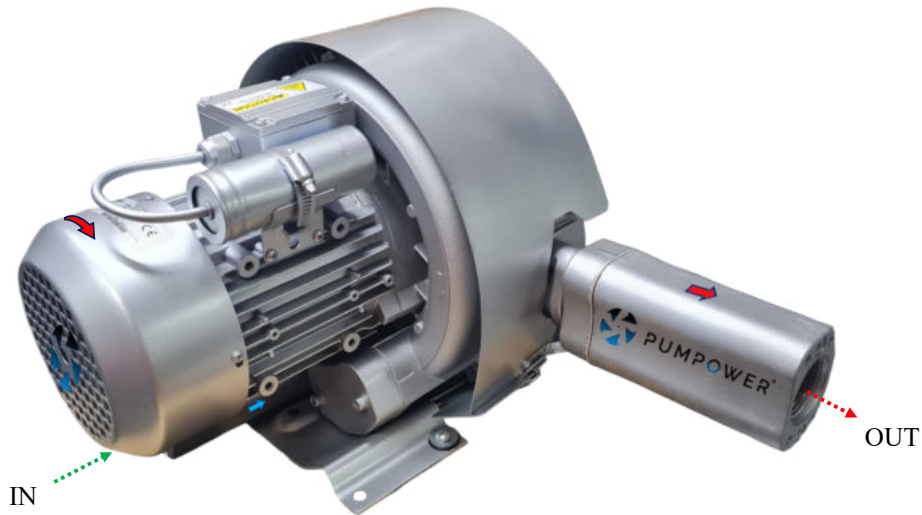
**Other voltage ranges**

50Hz

60Hz



3~

185...225 V D/320...390 V Y

200...240 V D/345...415 V Y

200...240 V D/345...415 V Y

200...275 V D/380...480 V Y

345...415 V D

380...480 V D

500 V D

575 V D

Machines according to the ATEX norm 94/4 EG are available for the whole performance range.

Following types available: Category 3 G, 3/2 G, 3 D and 3/2 D.

Further voltage range on request; please quote in plain text.

All PW achieve the standards and norms of the low voltage directive (LVD)2006/95/EC, rotating electrotechnical motor EN 60034-1-2004, electromagnetic compatibility(EMC)EN55014-1/2,EN61000-2/-3/-4/-6.

- 1) For standard UL for ELECTRIC MOTOR UL 1004-1.
- 2) Relief-valve are available for limiting differential pressure.
- 3) Measuring-surface sound-pressure level acc. to DIN EN 21680, measured at a distance of 1 m. The pump is throttled to an average suction pressure, a hose is connected to the discharge side (compressor) / suction side (vacuum pump), but is not fitted with relief valves.

The motors are designed according to the DIN EN 60 034 / DIN IEC 34-1 and temperature class F.

For the three phase machines the tolerances are +/- 10 % for fixed voltage and +/- 5 % for voltage range.

The single phase machines are designed with a +/- 5 % tolerances. If only 90 % of the maxium allowed pressure will be used for the continuousoperating then the allowed voltage range add to +/- 10 %.

For all single and three phase machines which designed according to the UL and CSA norm (UL 1004-1) the maximum allowed voltage tolerances are - 10 % resp. + 6 %.

The frequency tolerance is maximum +/- 2 %.





# PUMPOWER®

## BLOWER INDUSTRIAL

- Fabricados con tecnología alemana.
- Equipos de caudal - alto flujo de aire [2.500 m<sup>3</sup>/h].
- Equipos de alta presión [1.000 mBar].
- Libre de mantenimiento.
- Niveles de ruido bajo.
- Rodamientos originales de alta calidad.
- Funcionamiento libre de aceites, aire limpio.
- Fácil instalación.
- Precio competitivo.
- Diferentes diseños incluyendo una etapa, dos etapas y tres etapas.
- Garantía Amplia.
- Diferentes tipos de conexión: monofásica 110V - 220V, trifásica 220V - 440V.
- Algunas aplicaciones:
  - Oxigenación en estanques diseñados para la piscicultura, acuicultura y/o afines, en tierra y/o geomembrana.
  - Aireación y extracción de gases en la minería.
  - Secado de pintura automotriz.
  - Aspiradoras industriales para lavaderos de carros.
  - Oxigenación en plantas de tratamiento de aguas residuales.
  - Secado de papel.
  - Entre otros.

- |   |  |
|---|--|
| 1 Tapa posterior del Blower.            | 6 Flecha de dirección del transporte del fluido. |
| 2 Tapa delantera del Blower.            | 7 Flecha que indica el sentido de rotación.      |
| 3 Conexión - ducto de succión/vacío.    | 8 Motor asíncrono.                               |
| 4 Conexión - ducto de descarga/presión. | 9 Tapa del ventilador.                           |
| 5 Base para instalación.                | 10 Caja de bornes/terminales.                    |

